

**MODEL 6201-1369-TL**

**TOP LEFT CASTING**

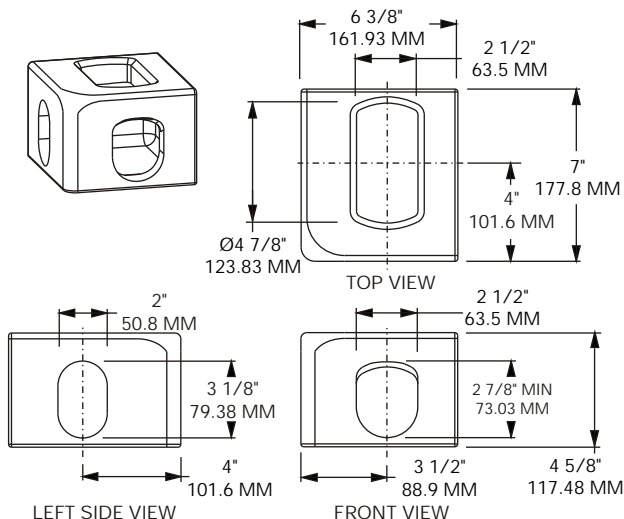

**MODEL 6201-1370-TR**

**TOP RIGHT CASTING**

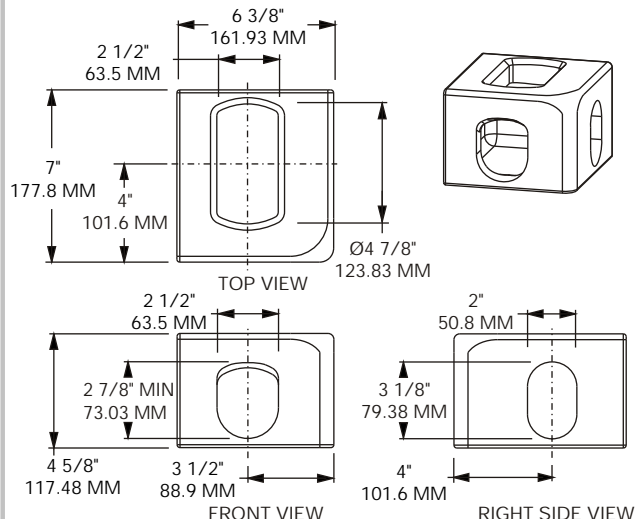

**MODEL 6201-1371-BL**

**BOTTOM LEFT CASTING**

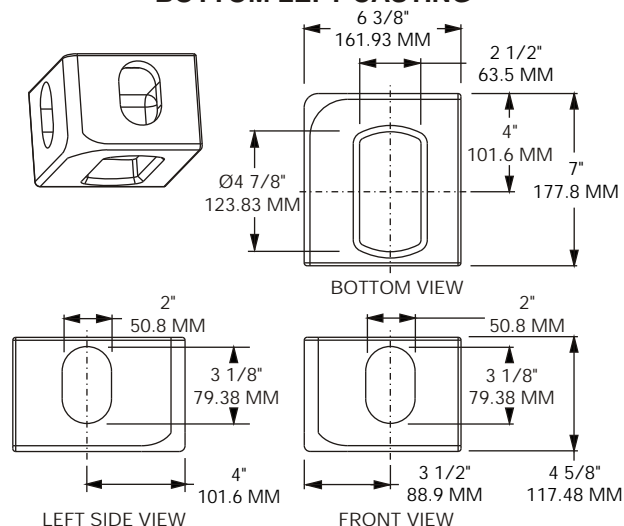

**MODEL 6201-1372-BR**

**BOTTOM RIGHT CASTING**

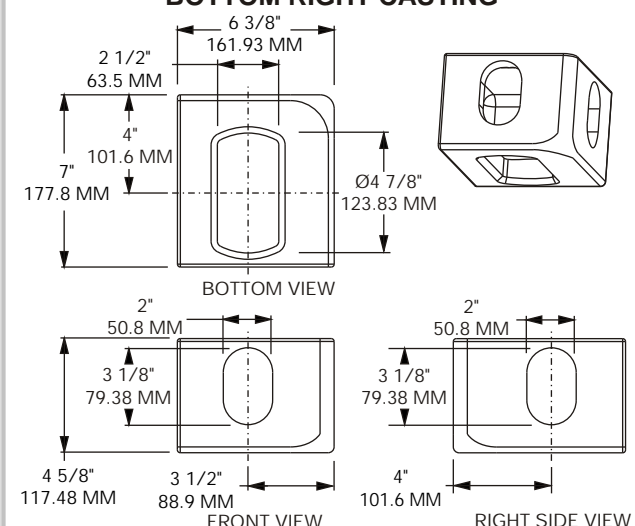

6200

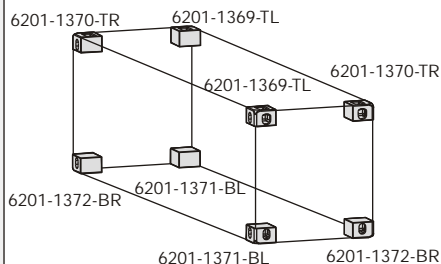

NOTE: STANDARD ISO CONTAINERS USE 8 EA. CORNER CASTINGS CONSISTING OF:  
 2 PCS TOP LEFT MODEL 6201-1369-TL WEIGHT: 23.0 LBS / 10.43 Kg  
 2 PCS TOP RIGHT MODEL 6201-1370-TR WEIGHT: 23.0 LBS / 10.43 Kg  
 2 PCS BOTTOM LEFT MODEL 6201-1371-BL WEIGHT: 24.0 LBS / 10.89 Kg  
 2 PCS BOTTOM RIGHT MODEL 6201-1372-BR WEIGHT: 24.0 LBS / 10.89 Kg  
 MATERIAL: ASTM A27 GR 70-36 OR EQUIV.  
 FINISH: MACHINED ALL SIX SIDES AND SHOT BLASTED

MANUFACTURED IN ACCORDANCE WITH APPROVAL CERTIFICATES BY LLOYD'S REGISTER AND BUREAU VERITAS. CASTINGS MEET REQUIREMENTS OF ISO 1161 FOR ISO CONTAINERS