

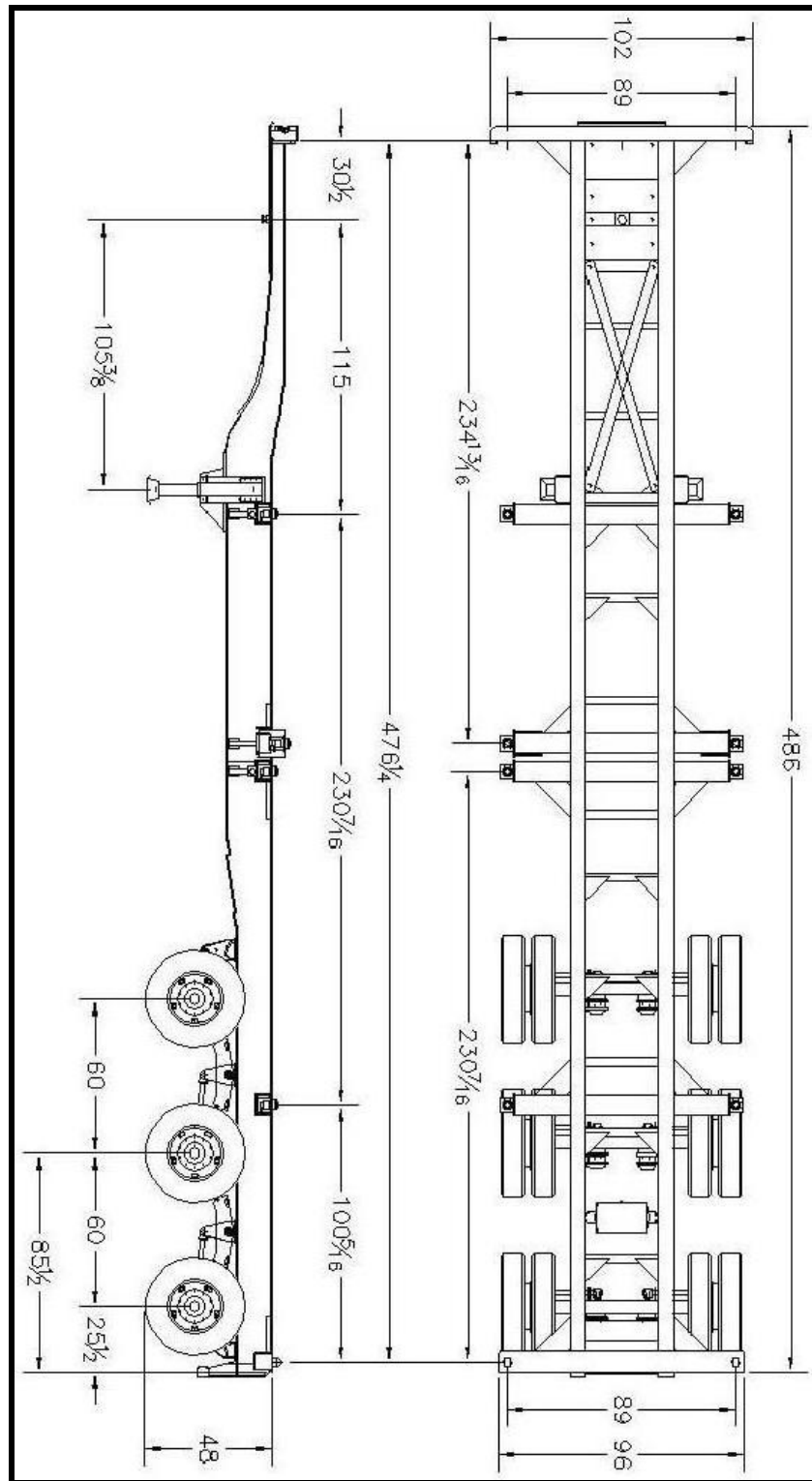

40' GN 12-PIN CHASSIS

New container chassis designed for repeated use in stevedoring and transporting of one 40ft, two 20ft, or one heavy 20ft (in center) ISO type cargo containers. Meets all AAR, FMVSS, ISO, ANSI, DOT, ABS, SAE and TTMA specifications at the time of manufacture and applicable to operation in the United States.

Overall Length:	40' – 8"
Overall Width:	96"
King Pin Location:	36"
Coupler Height:	48"
Tare Weight:	10,800 lbs approx
Main Rails:	Fabricated high strength steel main beams.
Landing Gear:	Two-speed mechanism and square leg tubing with 10" x 10" low profile sand shoes
Suspension:	Hutch with Three Leaf Springs (11,000 lb capacity each)
Axles:	Three Axles of 5" round and 22,500 lb beam capacity each; 16.5x 7-inch Q brakes; automatic type slack adjusters
Brake System:	Meritor Wabco 2S/1M Anti-lock Braking System; 30/30 Spring brake chambers
Tires / Wheels	11R22.5 tires on 10 hole disc wheels
Electrical/ Lights:	12 Volt with plug type connectors, 7-way plug, sealed wire harnesses and lights
Twist Locks	Cast steel to engage ISO corner castings
Paint:	Commercial sandblast, primer, and high quality paint system
Other:	Conspicuity Tape, Bumper, 24x30 Mud Flaps



Call Chassis King at 727-585-1500 for more info !